



Speedrail Side Palm Fixing

Product Data Sheet



A magnesium alloy pipe fitting.	
Part Nos	T194050
Tube Diameter	Ø48.3mm
Materials	Magnesium Alloy 535 Fixings - Grade 8.8 BZP
Max Tightening Torque	22Nm
WLL	N/A
Weight	0.34Kg

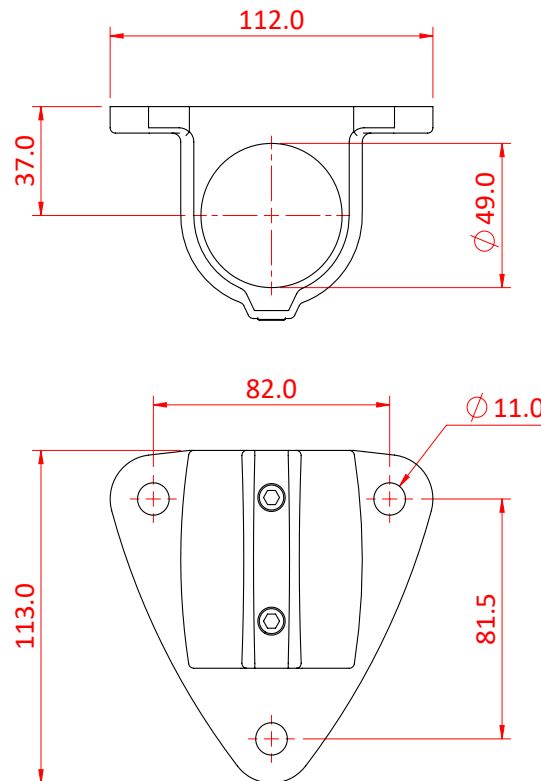

DIMENSIONS ARE A GUIDE ONLY AND MAY VARY

Doughty Engineering Ltd - Crow Arch Lane, Ringwood, Hampshire, BH24 1NZ, UK
+44 (0) 1425 478961, sales@doughty-engineering.co.uk - www.doughty-engineering.co.uk